

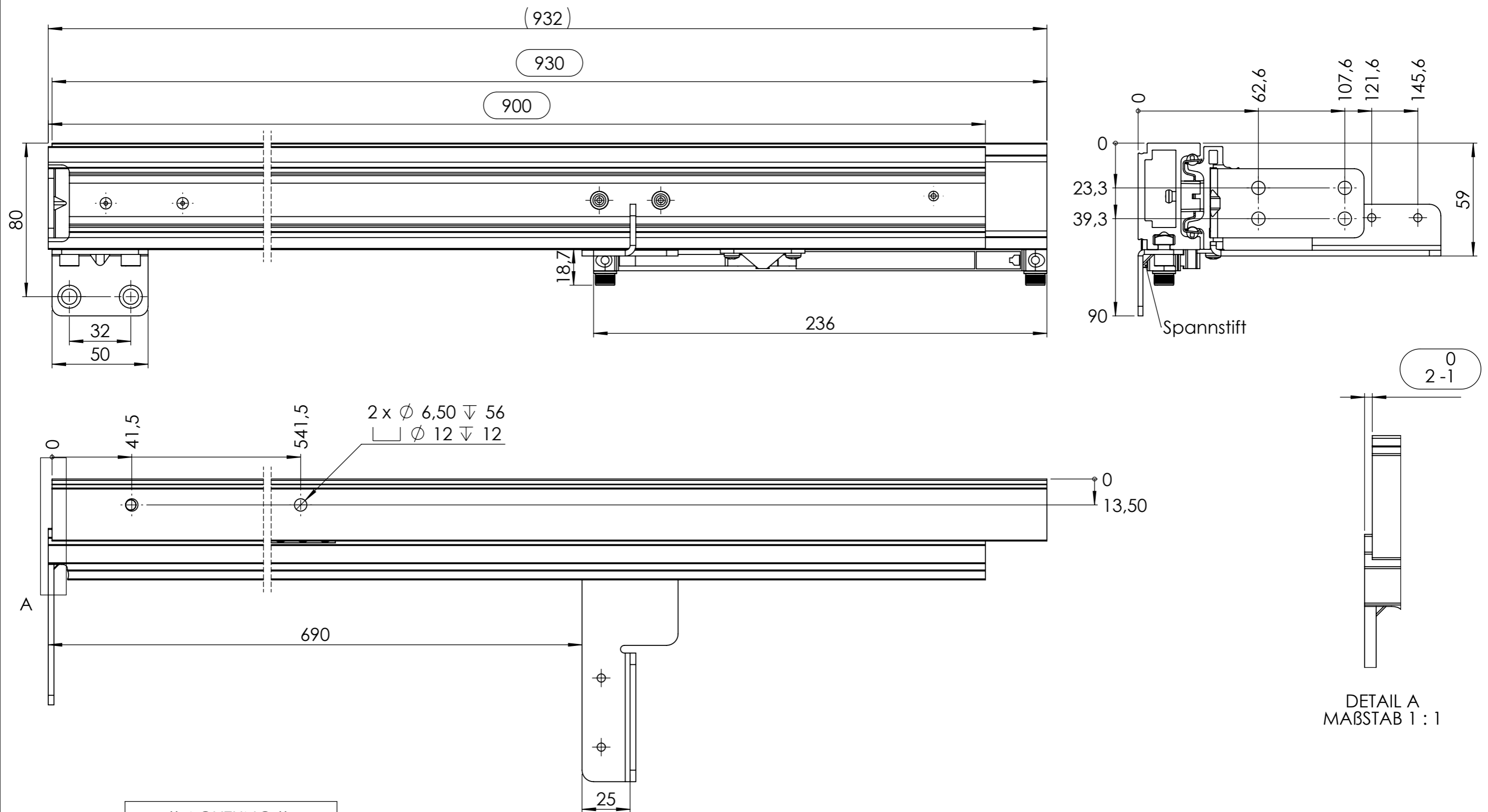

All property rights and rights to exploitation of copyright for this drawing data remain ours; they may not be made available to third parties without our consent.



**!! ACHTUNG !!
BEIPACK-INFORMATION
BEACHTEN**

Pos.11	15776
Pos.13	15751
Pos.10	15777

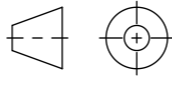
way of travel : ca. **753mm**

Index	Change			Date	Name
 DIN ISO 128-30	Description: A5FB/930.A55/900.A55/KK4/AS/li.				
	Surface:		Material: diverse		Weight: 3.28 kg
 PÖTTKER Transforming furniture	Name	Date	Company		
	Signed	A. Wewior	18.03.2020		
	Tested	A. Wewior	18.03.2020	Second Company:	
General tolerance: DIN ISO 2768 - m		Item No:	55093601	Scale 1:2	Page 1/8
					A3

CLOSE

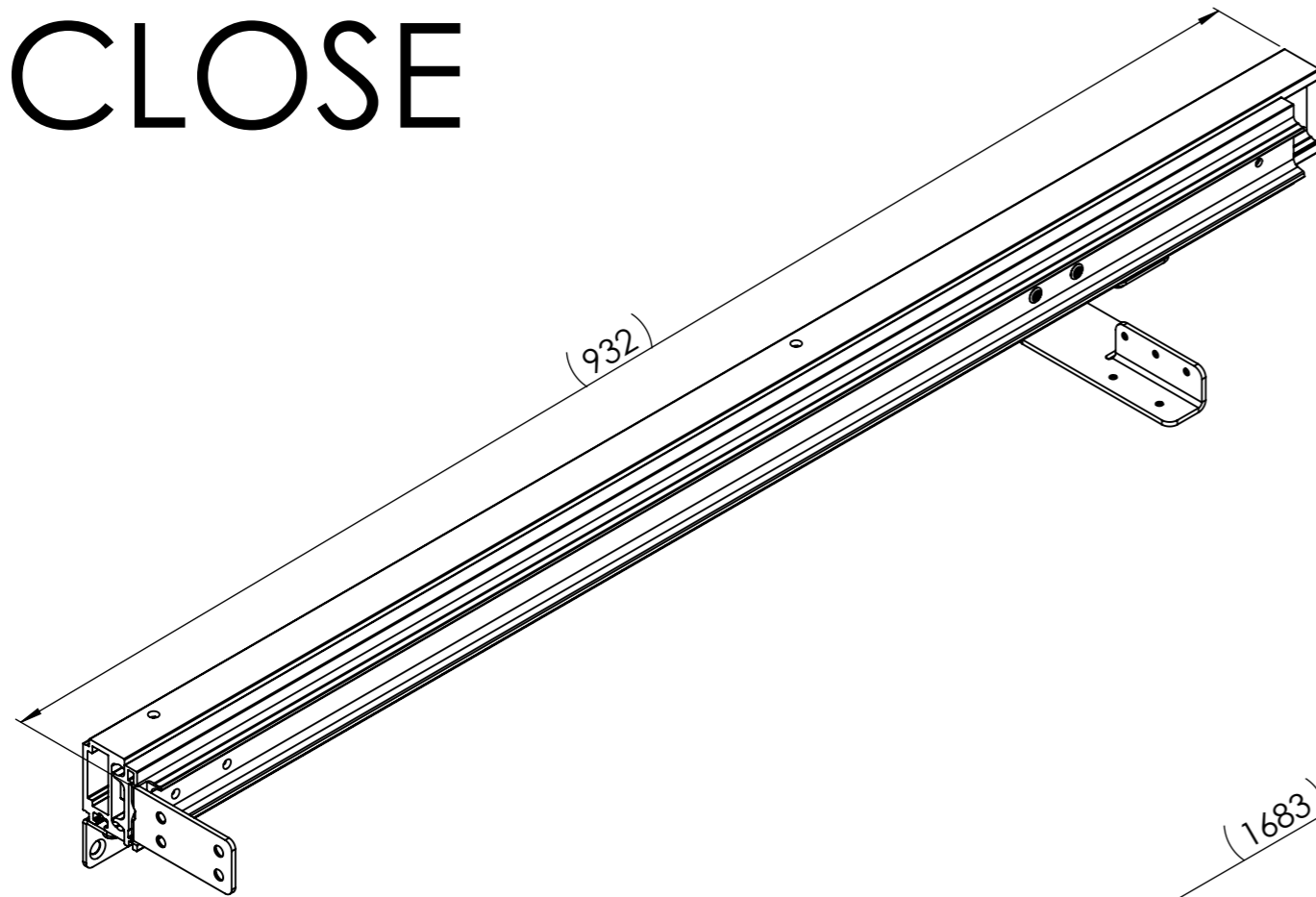

(932)

OPEN

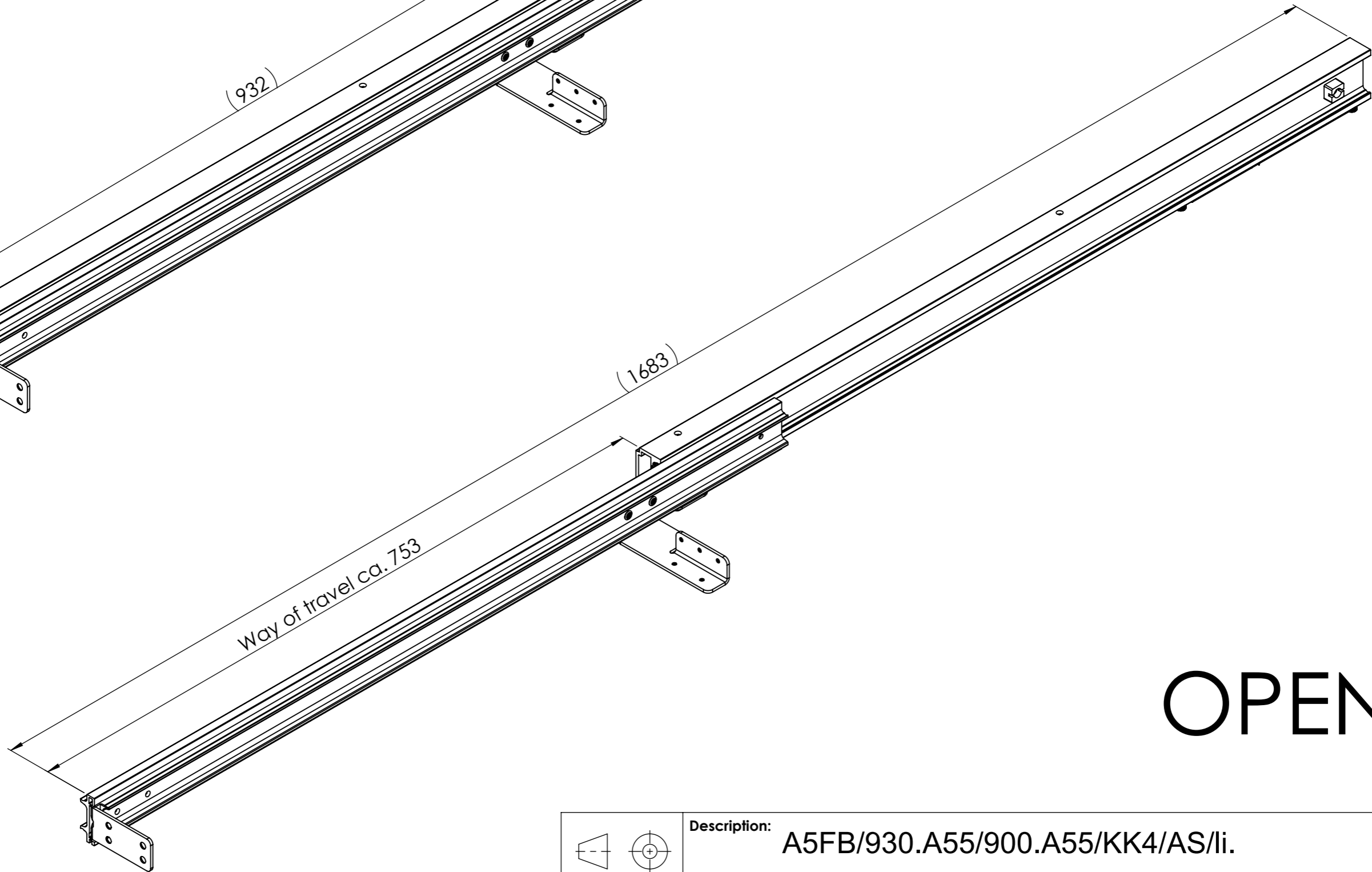

(1683)

Way of travel ca. 753

<p>DIN ISO 128-30</p>	Description: A5FB/930.A55/900.A55/KK4/AS/li.					
	Surface:		Material: diverse		Weight: 3.28 kg	
<p>PÖTTKER Transforming furniture</p>		Name	Date	Company		
	Signed	A. Wewior	18.03.2020			
	Tested	A. Wewior	18.03.2020	Second Company:		
General tolerance: DIN ISO 2768 - m		Item No: 55093601		Scale: 1:4	Page: 2/8	A3

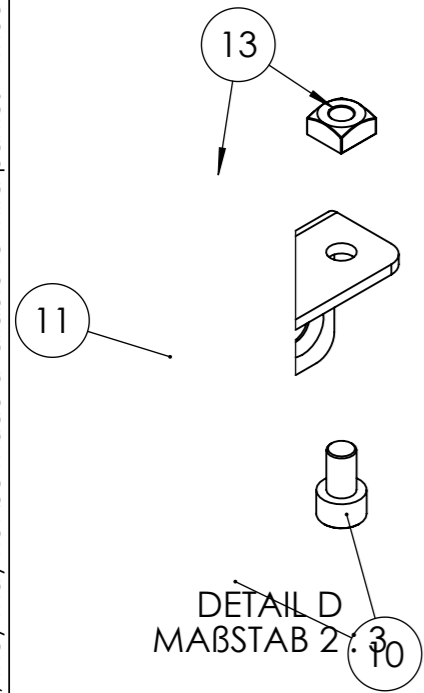

All property rights and rights to exploitation of copyright for this drawing data remain ours; they may not be made available to third parties without our consent.

!! ACHTUNG !!
LOSE MITLIEFERN

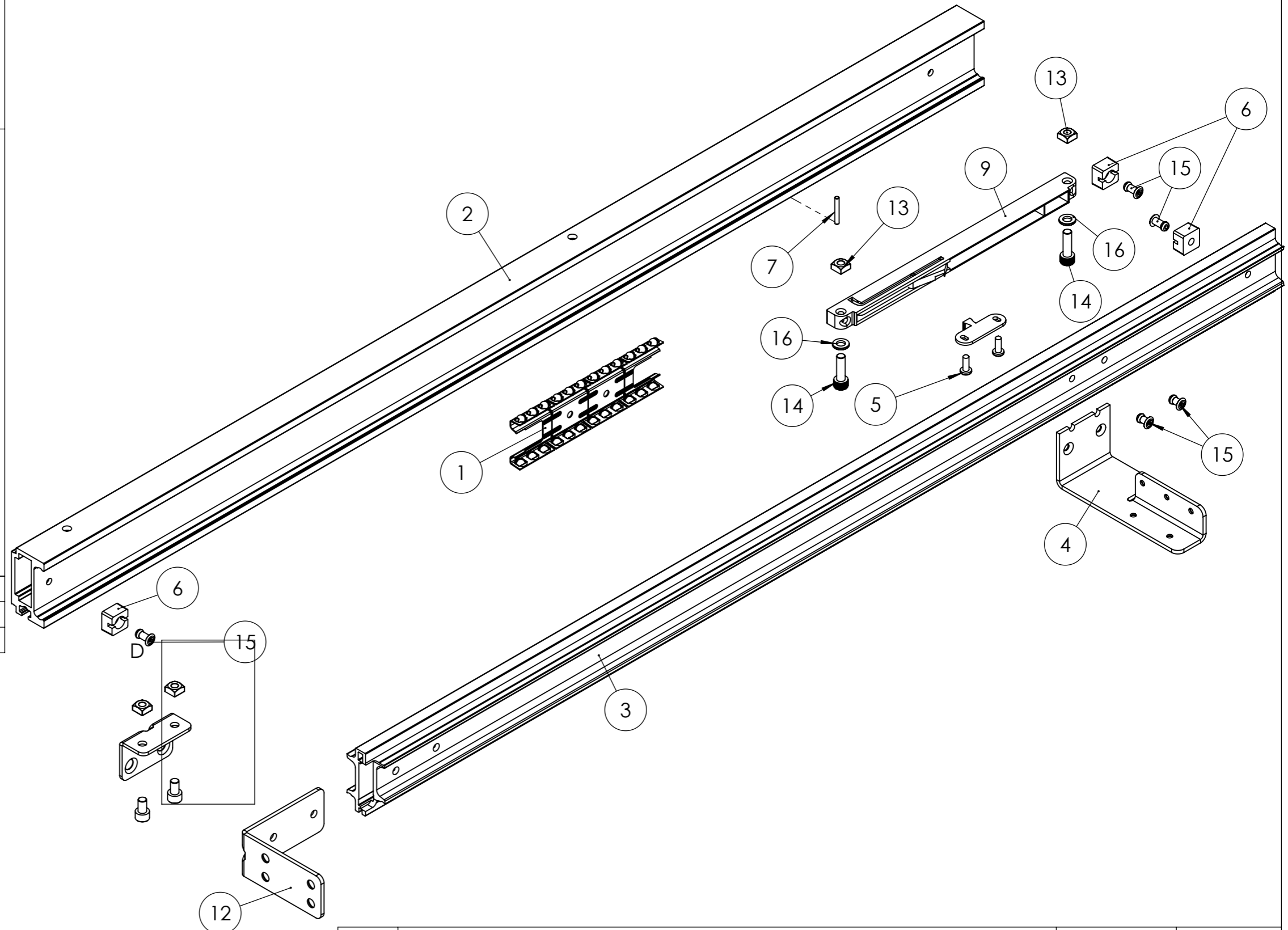

(2x) pro Paar	15776
(4x) pro Paar	15777
(4x) pro Paar	15751

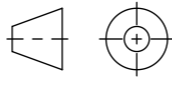

Index	Change			Date	Name
 DIN ISO 128-30	Description: A5FB/930.A55/900.A55/KK4/AS/li.				
	Surface:		Material: diverse		Weight: 3.28 kg
 Transforming furniture	Name	Date	Company		
	Signed	A. Wewior	18.03.2020		
	Tested	A. Wewior	18.03.2020	Second Company:	
General tolerance: DIN ISO 2768 - m		Item No:	55093601	Scale 1:3	Page 3/8
					A3

All property rights and rights to exploitation of copyright for this drawing data remain ours; they may not be made available to third parties without our consent.

All property rights and rights to exploitation of copyright for this drawing data remain ours; they may not be made available to third parties without our consent.

POS.	Item.No	Artikelbezeichnung	MENGE
1	56990125	KK47/4/AS/Al-Al (55er)	1
2	56093401	AP/A5FB/930.A55/li.	1
3	56090301	MPA/A5FB/900.A55/li.	1
4	22120904	Traverswinkel/50x3x120x46/V2/li./vz/S	1
5	16142	Bohrschraube+Linsenkopf, Ø3,9x13-DIN 7504M/Torx-vz	2
6	16053	Würfelstopp, 16x10x16/PA6.6-Plustek	3
7	15857	Spannstift/Ø3x22/ISO8752/C67	1
8	15780	Aktivator SP14 für Slidix II Selbsteinzug	1
9	15779	Selbsteinzug, Slidix II - 40Kg, 13N-Feder	1
10	15777	Zyl.-Schraube+Inbus, M6x10-DIN 912-vz	2
11	15776	Winkel zur Fußbefestigung/50x34,5x23,5x2,5	1
12	15775	Winkel zur Frontbefestigung/80x3x36x80	1
13	15751	Vierkantmutter, M6-DIN 557-vz	4
14	15499	Zyl.-Schraube+Inbus, M6x20-DIN 912-vz-gerändelt	2
15	15122	Blindniet Flachrundkopf, Ø5x12-AL/St.(6,0-8,0)	5
16	15002	U-Scheibe/Ø12xØ6,5x1,5-DIN 125-vz	2

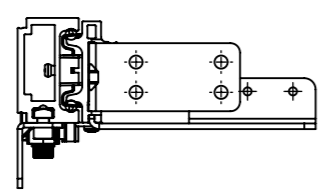

Index	Change		Date	Name	
 DIN ISO 128-30	Description: A5FB/930.A55/900.A55/KK4/AS/li.				
	Surface:		Material: diverse	Weight: 3.28 kg	
 Transforming furniture	Name	Date	Company		
	Signed	A. Wewior	18.03.2020		
	Tested	A. Wewior	18.03.2020	Second Company:	
General tolerance: DIN ISO 2768 - m		Item No: 55093601	Scale 1:4	Page 4/8	A3

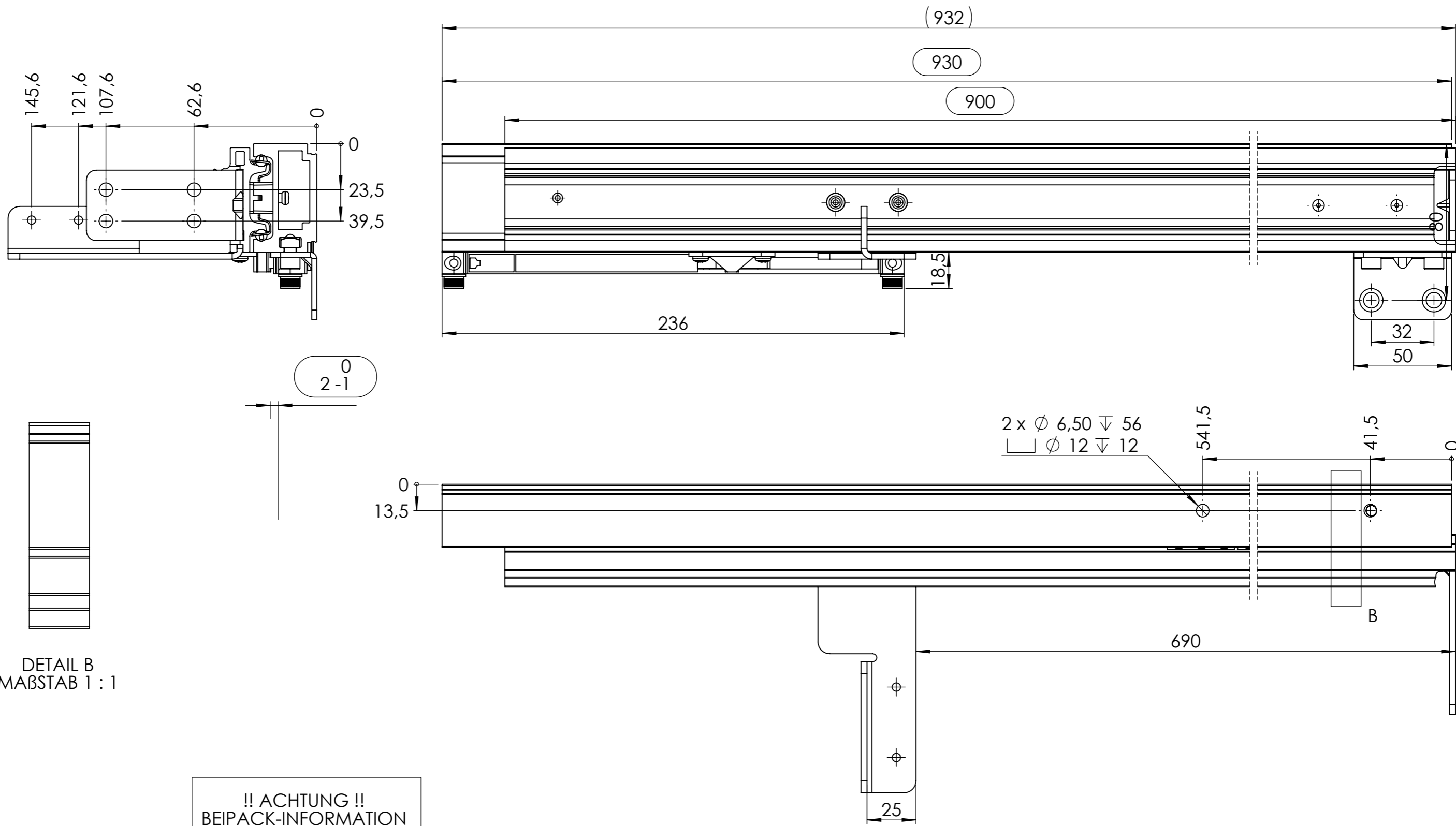

All property rights and rights to exploitation of copyright for this drawing data remain ours; they may not be made available to third parties without our consent.



**!! ACHTUNG !!
BEIPACK-INFORMATION
BEACHTEN**

Pos.11	15776
Pos.13	15751
Pos.10	15777

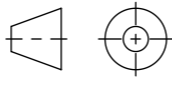
way of travel : ca. **753** mm

Index	Change		Date	Name	
 DIN ISO 128-30	Description: A5FB/930.A55/900.A55/KK4/AS/re.				
	Surface:		Material: diverse	Weight: 3.28 kg	
 Transforming furniture	Name	Date	Company		
	Signed	A. Wewior	18.03.2020		
	Tested	A. Wewior	18.03.2020	Second Company:	
General tolerance: DIN ISO 2768 - m		Item No: 55093601	Scale 1:2	Page 5/8	A3

CLOSE

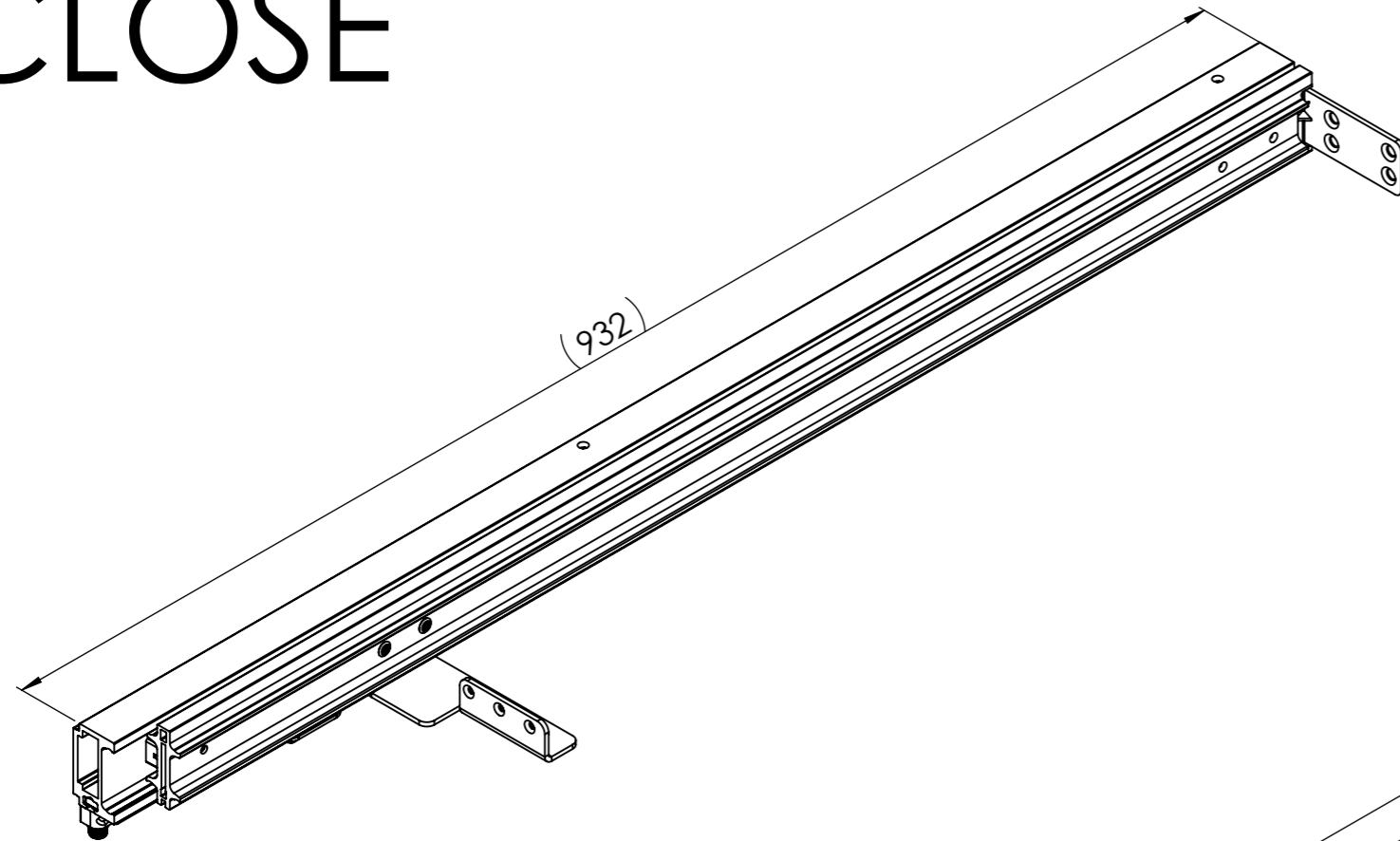

OPEN

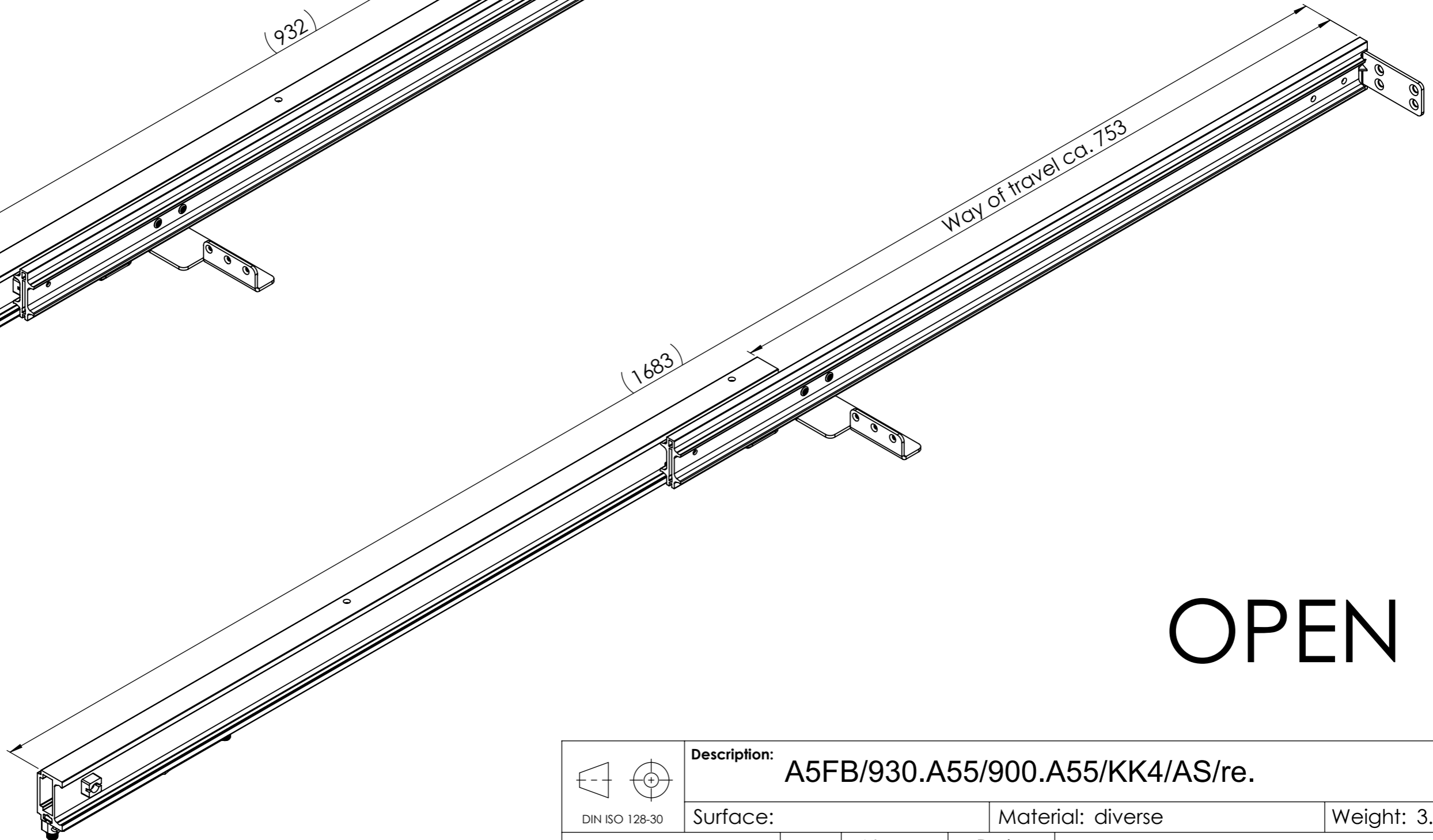

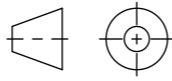
 DIN ISO 128-30	Description: A5FB/930.A55/900.A55/KK4/AS/re.				
	Surface:		Material: diverse		Weight: 3.28 kg
PÖTTKER Transforming furniture		Name	Date	Company	
	Signed	A. Wewior	18.03.2020		
	Tested	A. Wewior	18.03.2020	Second Company:	
General tolerance: DIN ISO 2768 - m		Item No: 55093601	Scale 1:4	Page 6/8	A3

All property rights and rights to exploitation of copyright for this drawing data remain ours; they may not be made available to third parties without our consent.

!! ACHTUNG !!
LOSE MITLIEFERN

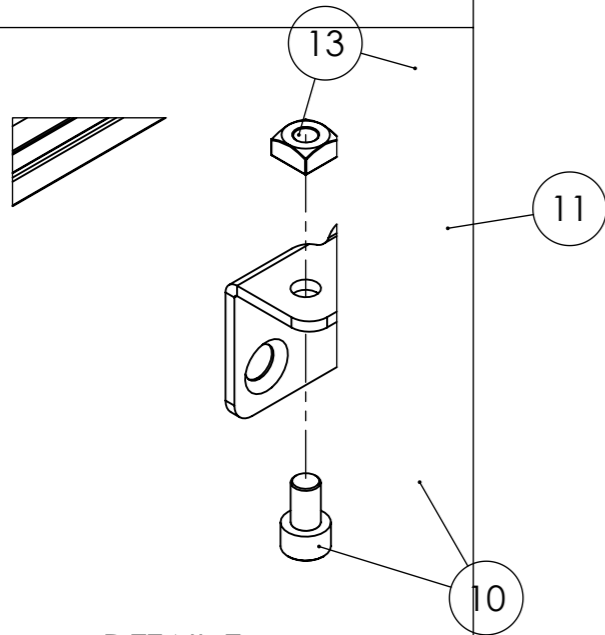

DETAIL E
MABSTAB 2 : 3

(2x) pro Paar	15776
(4x) pro Paar	15777
(4x) pro Paar	15751

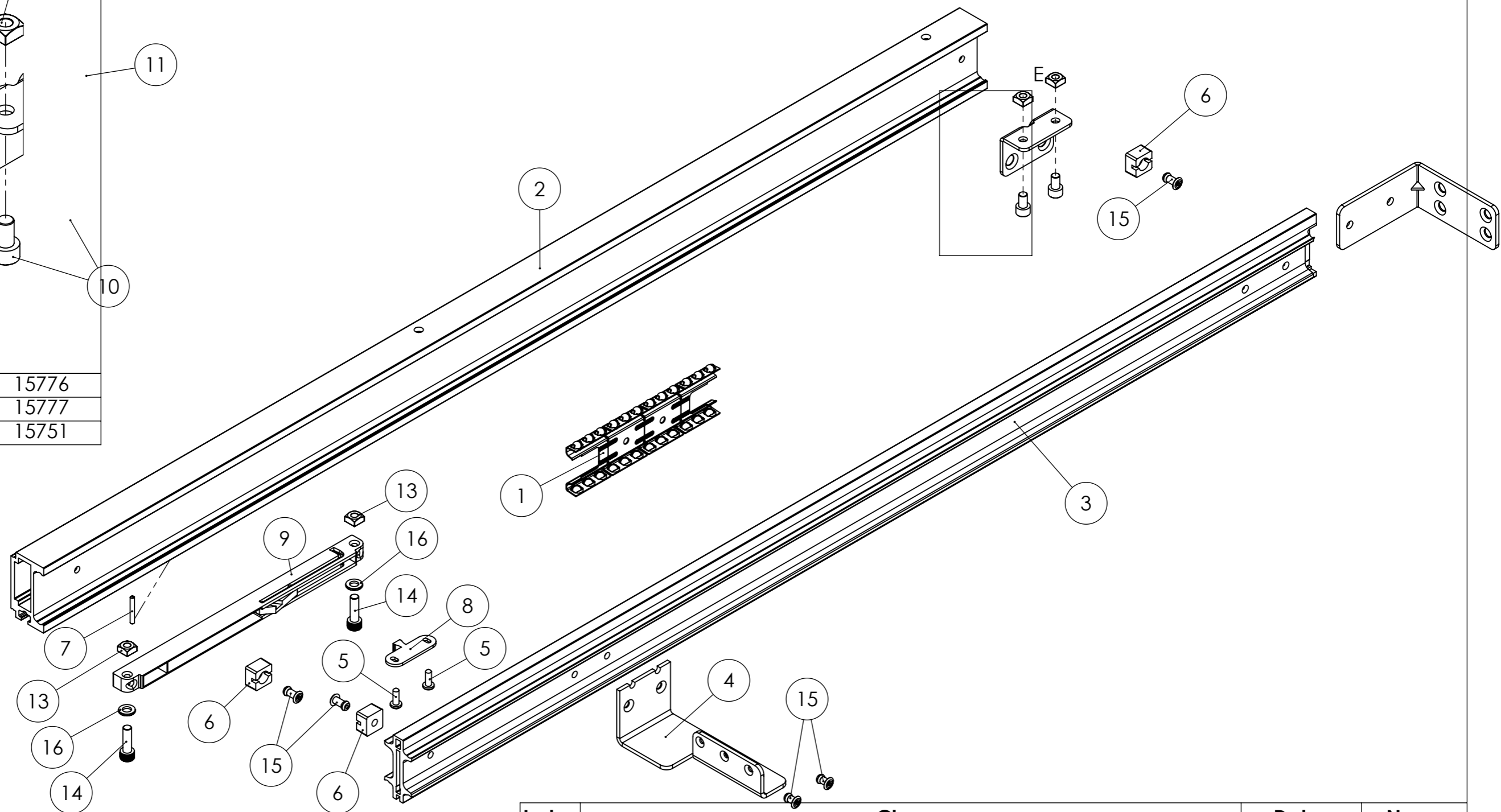

Index	Change		Date	Name
 DIN ISO 128-30	Description: A5FB/930.A55/900.A55/KK4/AS/re.			
	Surface:		Material: diverse	Weight: 3.28 kg
 Transforming furniture	Name	Date	Company	
	Signed	A. Wewior	18.03.2020	Second Company:
Tested	A. Wewior	18.03.2020		
General tolerance: DIN ISO 2768 - m		Item No: 55093601	Scale 1:3	Page 7/8 A3

All property rights and rights to exploitation of copyright for this drawing data remain ours; they may not be made available to third parties without our consent.

All property rights and rights to exploitation of copyright for this drawing data remain ours; they may not be made available to third parties without our consent.

POS.	Item.No	Artikelbezeichnung	Menge
1	56990125	KK47/4/AS/Al-Al (55er)	1
2	56093402	AP/A5FB/930.A55/re.	1
3	56090302	MPA-A5FB/900.A55/re.	1
4	22120903	Traverswinkel/50x3x120x46/V2/re./vz/S	1
5	16142	Bohrschraube+Linsenkopf, Ø3,9x13-DIN 7504M/Torx-vz	2
6	16053	Würfelstopp, 16x10x16/PA6.6-Plustek	3
7	15857	Spannstift/Ø3x22/ISO8752/C67	1
8	15780	Aktivator SP14 für Slidix II Selbsteinzug	1
9	15779	Selbsteinzug, Slidix II - 40Kg, 13N-Feder	1
10	15777	Zyl.-Schraube+Inbus, M6x10-DIN 912-vz	2
11	15776	Winkel zur Fußbefestigung/50x34,5x23,5x2,5	1
12	15775	Winkel zur Frontbefestigung/80x3x36x80	1
13	15751	Vierkantmutter, M6-DIN 557-vz	4
14	15499	Zyl.-Schraube+Inbus, M6x20-DIN 912-vz-gerändelt	2
15	15122	Blindniet Flachrundkopf, Ø5x12-AL/St.(6,0-8,0)	5
16	15002	U-Scheibe/Ø12xØ6,5x1,5-DIN 125-vz	2

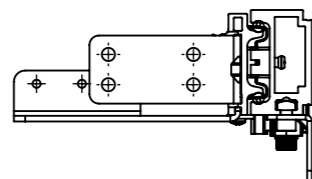

Index	Change		Date	Name	
 DIN ISO 128-30	Description: A5FB/930.A55/900.A55/KK4/AS/re.		Weight: 3.28 kg		
	Surface:				Material: diverse
 Transforming furniture	Name	Date	Company		
	Signed	A. Wewior	18.03.2020		
	Tested	A. Wewior	18.03.2020	Second Company:	
General tolerance: DIN ISO 2768 - m		Item No: 55093601	Scale 1:4	Page 8/8	A3